

C28 Advanced Ceramic Standards

Visit the C28 website (<http://www.astm.org/COMMIT/COMMITTEE/C28.htm>) to purchase C28 standards or join the C28 committee.

Monolithics

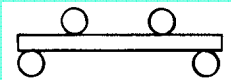

C 1161 Flexural strength
C 1211 Flexural strength (High Temp)
C 1368 Slow Crack Growth (Dynamic Fatigue)
C 1465 Slow Crack Growth (High Temp)
C 1576 Slow Crack Growth (Stress Rupture)
C 1684 Flexural strength (Rods)

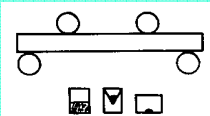

C 1421 Fracture Toughness

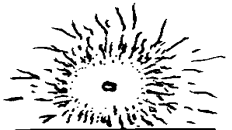

C 1322 Fractography
C 1678 Fracture Mirror

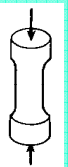

C 1424 Compression strength

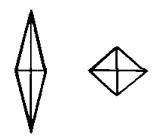

C 1326 Knoop hardness
C 1327 Vickers hardness

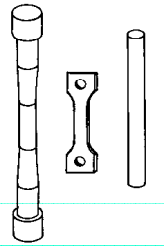

C 1273 Tensile strength
C 1366 Tensile strength (High T.)
C 1291 Creep, Creep Rupture
C 1361 Cyclic fatigue



C 1499 Biaxial strength

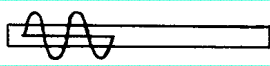

C 1198 Elastic Modulus - continuous
C 1259 Elastic modulus - impulse

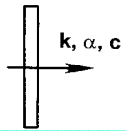

C 1470 Thermal Guide

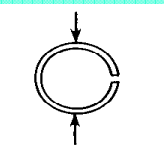

C 1323 C-ring strength

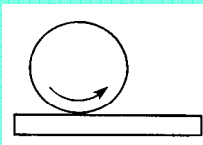

C 1495 Grinding

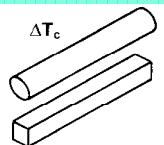

C 1525 Thermal shock

Composites, Coatings, Porous Ceramics



C 1275 CFCC Tensile strength
C 1359 Tensile strength (Hi Temp)
C 1337 Creep, Creep Rupture
C 1360 Cyclic fatigue

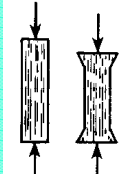

C 1358 CFCC Compression

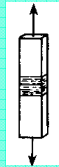

C 1341 CFCC Flexure strength



C 1674 Honeycomb Flex strength

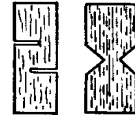

C 1292 CFCC Shear strength
C 1425 Shear strength (HiTemp)

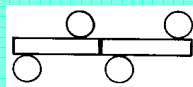

C 1469 Joint strength

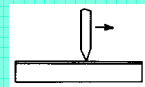

C 1624 Coatings - Scratch Adhesion

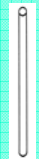

C 1557 Filament Tensile strength and Elastic modulus

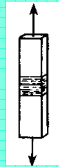

C 1468 CFCC Tensile Trans thickness

Powders

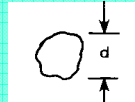

C 1274 Particle size, BET
C 1282 Particle size, Centrifugal Sed.

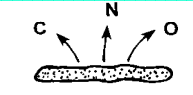

C 1494 C, N, O in silicon nitride

- Subcommittees**
- .01 Mech. Prop. + Reliability
 - .03 Physical Prop. + NDE
 - .04 Applications
 - .07 Ceramic Matrix Composites
 - .91 Terminology
 - .94 ISO TAG

NDE and Design



C 1239 Weibull

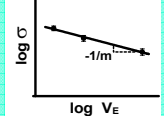

C 1683 Weibull Scaling



C 1212 Seeded voids
C 1336 Seeded inclusions

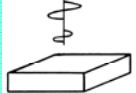

C 1331 Ultrasonic velocity
C 1332 Ultrasonic attenuation

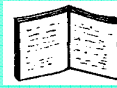

C 1175 NDE Guide

Terms, Workshops, Education



STP 1201 Life Prediction
STP 1309 Composites
STP 1392 Composites
STP 1409 Fracture

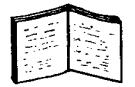

C 1145 Terminology