

ENGINEERING DIELECTRICS

Volume II B

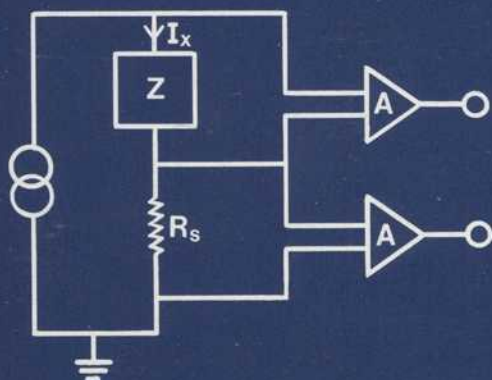

Electrical Properties of
Solid Insulating Materials:
Measurement Techniques

R. Bartnikas, editor

ASTM STP 926

ENGINEERING DIELECTRICS

Volume IIB

Electrical Properties of Solid Insulating Materials: Measurement Techniques

R. Bartnikas

Editor

Institut de Recherche d'Hydro-Quebec

Varenes, Quebec, Canada



SPECIAL TECHNICAL PUBLICATION 926
1916 Race Street, Philadelphia, Pa. 19103

Library of Congress Cataloging-in-Publication Data
(Revised for vol. 2-B)

Engineering dielectrics.

(ASTM special technical publication; 669,)
"ASTM publication code number (PCN) 04-926000-21."

Contents: v. 1. Corona measurement and interpretation.—v. 2., pt. A. Electrical properties of solid insulating materials.—v. 2, pt. B. Electrical properties of solid insulating materials: measurement techniques.

1. Electric insulators and insulation—Collected works. I. Bartnikas, R. II. McMahon, E. J. (Eugene Joseph) III. ASTM Committee D-9 on Electrical Insulating Materials. IV. ASTM special technical publication; 669, etc.

TK3401.E53 621.319'37 78-72477
ISBN 0-8031-0491-X

STP 926 is sponsored by ASTM Committee D-9 on Electrical Insulating Materials

Copyright © by AMERICAN SOCIETY FOR TESTING AND MATERIALS 1987
Library of Congress Catalog Card Number: 78-72477
ASTM Publication Code Number (PCN): 04-926000-21

NOTE

The Society is not responsible, as a body,
for the statements and opinions
advanced in this publication.

Foreword

The present publication, Volume IIB, constitutes a part of a monograph series entitled *Engineering Dielectrics*. The subject matter of the series encompasses various practical and theoretical facets of dielectric materials that are suitable for use in electrical apparatus, cables, and devices. The series consists of eight volumes, namely:

- Volume I Corona Measurement and Interpretation (*ASTM STP 669*)
- Volume IIA Electrical Properties of Solid Insulating Materials:
Molecular Structure and Electrical Behavior (*ASTM STP 783*)
- Volume IIB Electrical Properties of Solid Insulating Materials:
Measurement Techniques (*ASTM STP 926*)
- Volume IIIA Solid-Liquid Insulating Systems: Impregnants
- Volume IIIB Solid-Liquid Insulating Systems: Impregnated Systems
- Volume IV Cable Insulating Systems
- Volume V Transformer and Rotating Machine Insulating Systems
- Volume VI Capacitor and Bushing Insulating Systems

The series is sponsored by ASTM Committee D-9 on Electrical Insulating Materials. The thoroughness with which the subject matter must be treated has caused some protraction of the publication dates of the individual volumes. Many enquiries have been received concerning the release of volumes that have not yet been published and are in various stages of preparation. In this regard, your patience and understanding are greatly appreciated. Since I have just completed my third and final consecutive term as chairman of ASTM Committee D-9, additional time has become available to me for writing and editing purposes. It is hoped that this will expedite the publication of future volumes.

R. Bartnikas
Editor

Related ASTM Publications

Engineering Dielectrics, Volume IIA—Electrical Properties of Solid Insulating Materials: Molecular Structure and Electrical Behavior, STP 783 (1983), 04-783000-21

Engineering Dielectrics, Volume I: Corona Measurement and Interpretation, STP 669 (1979), 04-669000-21

Contents

Foreword	iii
Preface	1
CHAPTER 1—Direct-Current Conductivity Measurements— R. BARTNIKAS	3
CHAPTER 2—Alternating-Current Loss and Permittivity Measurements—R. BARTNIKAS	52
CHAPTER 3—High Voltage Measurements—R. BARTNIKAS	157
CHAPTER 4—Surface Failure Measurements—K. N. MATHES	221
CHAPTER 5—Polymer Degradation and Its Measurement— K. D. WOLTER, J. F. JOHNSON AND J. TANAKA	313
CHAPTER 6—Electrostatic Charge Measurements— R. E. VOSTEEN AND R. BARTNIKAS	440
CHAPTER 7—Statistical Methods for the Evaluation of Electrical Insulating Systems—W. D. WILKENS	490
CHAPTER 8—Systems of Units—R. BARTNIKAS	530
APPENDICES	
I Units and Equivalents	543
II General Physical Constants	544
III Greek Alphabet	545
Subject Index	547
Author Index	573

A Need for Measurement:

. . . whenever I conceive any material or corporal substance, I immediately feel the need to think of it as bounded, and as having this or that shape; as being large or small in relation to other things, and in some specific place at any given time; as being in motion or at rest; as touching or not touching some other body; and as being one in number, or few, or many.

Galileo

SBN 0-8031-0491-X