

# The Relationship Between Engine Oil Viscosity and Engine Performance

## Part II

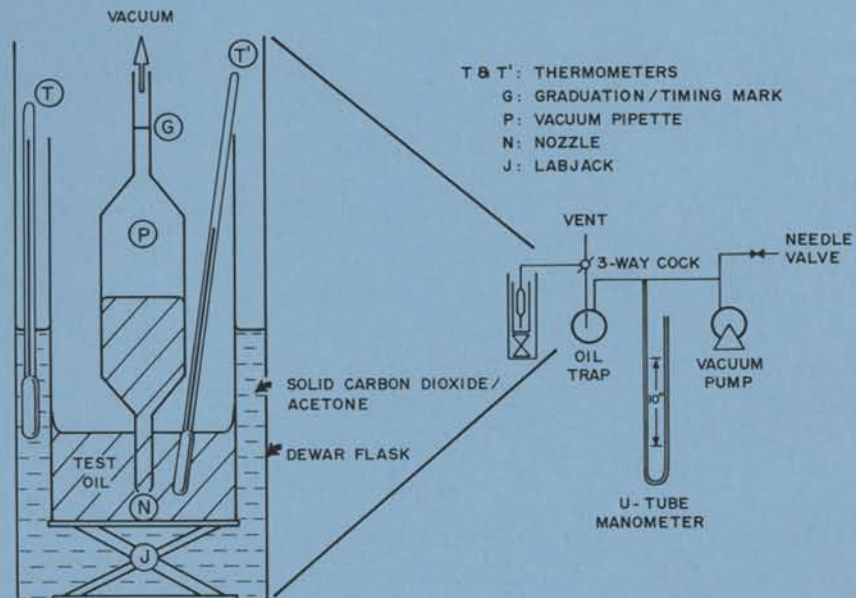

A Joint Publication of the  
Society of Automotive Engineers, Inc.  
SAE SP 419  
and  
American Society for Testing and Materials  
ASTM STP 621-S1



# **The Relationship Between Engine Oil Viscosity and Engine Performance - Part II**

Symposium Collected and Collated by  
R. M. Stewart  
T. W. Selby

Symposium Chairmen  
T. F. Lonstrup  
P. A. Bennett  
M. L. McMillan  
W. E. Waddey

Sponsored by  
Society of Automotive Engineers, Inc.  
and  
American Society for Testing and Materials

Presented at  
SAE Fuels & Lubricants Meeting  
Tulsa, Oklahoma      June 6 - 9, 1977

Published by  
Society of Automotive Engineers, Inc.  
400 Commonwealth Drive, Warrendale, PA 15096



## PREFACE

This SAE-ASTM Symposium entitled "The Relationship Between Engine Oil Viscosity and Engine Performance"—Part II (SAE SP 419-ASTM STP 621-S1) was presented at the SAE Fuels and Lubricants Meeting in Tulsa, Oklahoma, June 6-9, 1977. Part I (SAE SP 416 - ASTM STP 621) was presented earlier at the 1977 SAE International Automotive Engineering Congress and Exposition held in Detroit, Michigan, February 28-March 4, 1977.

These symposia were organized to encourage international sharing of information that could help in the development of a revised viscosity classification system based on engine performance.

Another goal of these symposia was to publicize the areas where more information is needed to design a realistic viscosity classification system. This should encourage the automotive, petroleum, and additive industries to obtain the needed data.

Ross M. Stewart

# Table of Contents

<b>The Relationship of Journal Bearing Wear to Multigrade Engine Oil Viscometric Properties (770627), R. L. Stambaugh, R. J. Kopko, and P. A. Bennett</b> .....	1
<b>Startability Benefits of Multigrade Diesel Oils (770629), A. R. Nolf.</b> .....	9
<b>Determination of the Cold Flow Behaviour of Multigrade Engine Oils (770630), Wilfried J. Bartz and Wolfgang Wiemann.</b> .....	17
<b>Low Temperature Viscosity Requirements for Engine Oils in Temperate and Tropical Climates (770631), P. R. King</b> .....	29
<b>Viscometer for Predicting Low-Temperature Pumpability of Engine Oils (770632), D. L. Alexander and S. W. Rein.</b> .....	37
<b>A Mathematical Technique for Comparing Shear Stability in Bench Tests and Service (770633), S. W. Rein, N. P. Randall, H. T. Marshall, and B. J. Lewis</b> .....	45



This paper is subject to revision. Statements and opinions advanced in papers or discussion are the author's and are his responsibility, not the Society's; however, the paper has been edited by SAE for uniform styling and format. Discussion will be printed with the paper if it is published

**Society of Automotive Engineers, Inc.**  
400 COMMONWEALTH DRIVE, WARRENDALE, PA 15096

in SAE Transactions. For permission to publish this paper in full or in part, contact the SAE Publications Division.

Persons wishing to submit papers to be considered for presentation or publication through SAE should send the manuscript or a 300 word abstract of a proposed manuscript to: Secretary, Engineering Activities Board, SAE.

**64**  
page booklet.

Printed in U.S.A.